

DTS 310

DIN – Rail Mounted, Indoor Rated Revenue Grade Electrical Sub-meter



1	PRODUCT OVERVIEW	3
1.1	SUPPLIED ITEMS	3
1.2	DOCUMENT CONVENTIONS	4
1.3	PRODUCT SPECIFICATION	4
1.3.1	Current Inputs	4
1.3.2	Service Type	4
1.4	DTS 310 LAYOUT	5
2	INSTALLATION	6
2.1	ENVIRONMENT	6
2.2	SAFETY GUIDELINES	6
2.3	PRODUCT DIMENSIONS	7
2.4	MOUNTING REQUIREMENTS AND GUIDELINES	7
3	CONNECTING TO THE DTS 310	8
3.1	WIRING VOLTAGE AND CURRENT INPUTS	8
3.1.1	Wiring Examples	8
3.2	CONNECTING MULTIPLE LOADS	9
3.3	DC AUXILIARY POWER	10
4	MAINTENANCE AND SERVICE	11
5	DTS 310 COMMUNICATIONS INTERFACE	11
5.1	MODBUS AND BACNET RS-485 2-WIRE COMMUNICATIONS	11
5.2	LONWORKS TP/FT – 10 COMMUNICATIONS	12
5.2.1	Wiring Requirements	12
5.2.2	Adding the DTS 310 to an existing LonWorks Network via Service Pin	12
5.2.3	Adding the DTS 310 to an existing LonWorks Network via Neuron ID	12
5.3	ETHERNET COMMUNICATIONS	13
5.4	KWH PULSE OUTPUT (MODEL DEPENDENT)	13
5.5	CONFIGURING DIP SWITCHES – COMMUNICATION AND PULSE OUTPUT SETTINGS	13
5.5.1	Configuring DIP Switches – Modbus RTU	14
5.5.2	Configuring DIP Switches – BACnet MS/TP	14
5.5.3	Configuring DIP Switches – Pulse Output	15
6	LED DEFINITIONS	16
6.1	STATUS LED	16
6.2	REMOTE LED	16
6.3	PULSE LED	17
7	INSTALLATION OF DTS CONFIG AND MONITORING SOFTWARE	17
8	MAINTENANCE AND SERVICE	17
8.1	CLEANING INSTRUCTIONS	17

1 PRODUCT OVERVIEW

The one revenue grade meter for all applications.

Your DTS 310 energy sub-meter is one of the most versatile meters available on the market. The DTS 310 can operate in any environment, requires no external power source to operate, and works with all UL or ETL listed 333mV current transformers.

For ease of installation, the DTS 310 is designed to be compact and fit into most DIN-rail systems.

Some of the exciting features provided with the DTS 310 are

- Easy to attach pluggable terminals
- RS-485 or Ethernet Communications depending on model
- Auto-topology Phase Detection and on-board CT Algorithms for automatic correction of reversed field mounted CTs

For remote configurability, your DTS 310 comes with our freely downloadable *DTS Config* software tool

The DTS 310 provides you very accurate data acquisition and is certified to ANSI C12.20 Class 0.5 Revenue Grade.

Also, if in the future, you decide to integrate renewable energy sources, the DTS 310 will conveniently operate as a Bi-Directional **NET** meter. Easily integrates with Building Automation Systems and Energy Monitoring Software.

Designed and Manufactured in the USA and complies with the Buy American Provisions of ARRA Section 1605.

Thank you for choosing Measurlogic and a meter from the DTS Family.



1.1 Supplied Items

Check that the meter and equipment matches your order specifications and has not been damaged during shipping. Verify that the following item(s) match with the corresponding model from the data sheet:

- Quick Start Guide
- DTS 310 power & energy meter
- 10-Pin green pluggable screw terminal connector for Voltage inputs
- 6-Pin green pluggable screw terminal connector for Current inputs
- 3-Pin green pluggable screw terminal connector for Remote RS-485 Communications depending on model
- 6-Pin green pluggable screw terminal connector for digital I/O depending on model

1.2 Document Conventions

SYMBOLS

	ATTENTION – PLEASE CONSULT THE INSTALLATION MANUAL
	WARNING – RISK OF ELECTRICAL SHOCK

1.3 Product Specification

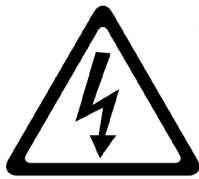

WARNING
The DTS 310 is intended for 480V L-L Measurement Category III use. Do NOT exceed this usage.
Use the model number of the DTS 310 to verify that it is suitable for the voltage, type and category of the installation.
Failure to use the correct CT's, and/or connecting too high a voltage can result in death or personal injury, and may permanently damage the DTS meter.

DTS 310 - **A**x-xx-x-**F**-xx

1.3.1 Current Inputs

Current Inputs	Value	Description	Notes
A	3	333mV CT	Any 333mV CT is acceptable
	9	Unburdened CT	Only use the CT's that came with the unit

1.3.2 Service Type

Service Type	Value	Description	Neutral Required	Neutral Optional
F	N	(1P 2W, 1P 3W, 3P 4W) 120 – 277Vac L– N	•	
	2	(3P 3/4W) 208 – 240 Vac L– L		•
	4	(3P 3W) 480 Vac L– L		•

1.4 DTS 310 Layout

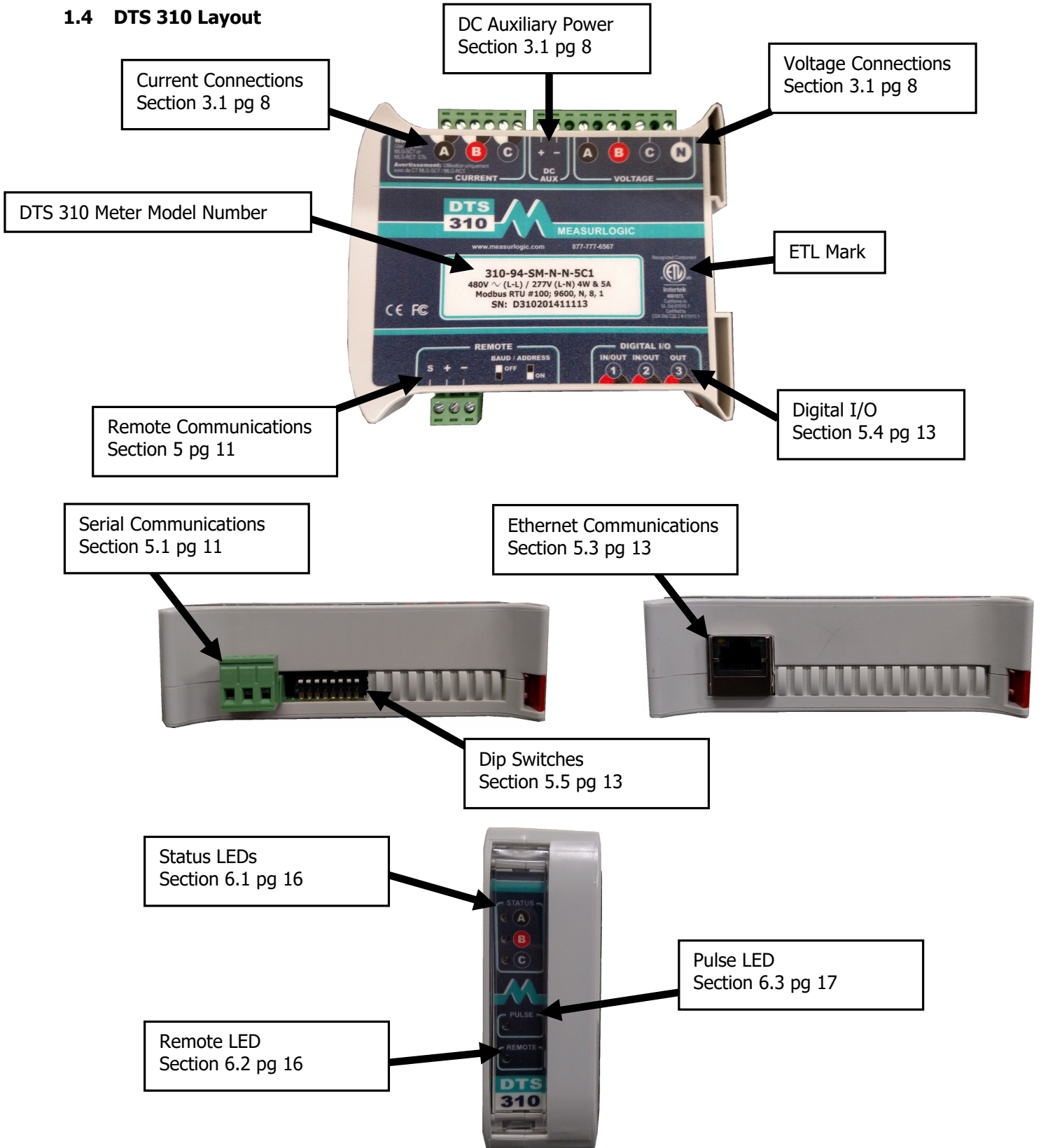

2 INSTALLATION

2.1 Environment

Operating Temperature:	-4°F to 131°F	(-20°C to 55°C)
Storage Temperature:	-40°F to 185°F	(-40°C to 85°C)
Relative Humidity:	5% to 95%	(non-condensing)
Operating Altitude:	Up to 2,000m	

2.2 Safety Guidelines



WARNING

The following installation instructions are intended for qualified personnel only. To avoid the risk of electrical shock and personal injury, do not perform additional tasks not stated in this procedure unless you are qualified to do so.

Always adhere to the following safety guidelines:

- Only qualified personnel or **licensed electricians** should handle the installation. Input voltages to the DTS 310 can be hazardous.
- Follow all applicable local and national electric codes.
- Verify input voltage and current are within thresholds for the specific DTS 310 model. (See Product Specification on page 4)
- Use only UL or ETL listed current transformers.
- **ONLY USE CURRENT TRANSFORMERS WITH OUTPUTS THAT ARE COMPATIBLE WITH THE MODEL OF DTS 310 (SEE SECTION 1.3.1). THE USE OF ANY OTHER CURRENT TRANSFORMER CAN RESULT IN PERMANENT DAMAGE TO THE DTS 310.**
- Avoid any electrostatic discharge prior to working on the DTS 310 by first touching a grounded structure prior to handling the DTS 310.
- Before applying power make sure that all current transformer and voltage connections are securely connected to the input terminals of the DTS 310.
- If the DTS 310 is installed incorrectly any built in safety features may no longer be functional.
- Before handling the DTS 310 ensure that all power running to the DTS 310 is removed.
- The DTS 310 is for indoor use only, and **MUST** be mounted in a NEC compliant enclosure suitable for the environmental conditions and locked with a **user supplied lock**.

2.3 Product Dimensions

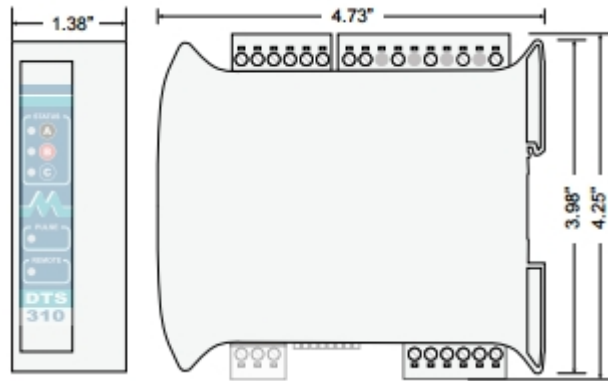

2.4 Mounting Requirements and Guidelines



ATTENTION

Make sure to follow the following mounting requirements and guidelines when mounting the DTS 310.

When mounting the DTS 310 make sure to follow these guidelines:

- Mount the DTS 310 as close as possible to the electrical panel being monitored.
- Make sure that there is at least 4" of clearance above and below the DTS 310 for wiring and connector clearance and ¼" of clearance on both sides for cooling.
- Position the DTS 310 such that the labeling can be read from the upright position.
- Only UL or ETL rated conduits and glands should be used.
- It is recommended that two separate conduits be run for voltage and current connections.
- **User Supplied** UL or ETL certified 2A fast-blow fuses need to be installed between the Voltage inputs of the DTS 310 and panel being monitored. Recommended Littelfuse BLS002 or equivalent.
- 14 to 12 AWG wire should be used for the voltage and ground with 300V or 600V insulation depending on installation type and according to the table below.
- A UL or ETL certified 600V circuit-breaker or fused disconnect must be installed within easy reach of the DTS 310. The circuit-breaker or fused disconnect must be clearly marked as being "**the disconnecting device**" for the DTS 310. See table below for the breaker and wire gauge to use.

WIRE & BREAKER GUIDE	
Gauge of Wire	Recommended Breaker
14 AWG	15 Amp 600V 3-Pole Breaker
12 AWG	20 Amp 600V 3-Pole Breaker

3 CONNECTING TO THE DTS 310

3.1 Wiring Voltage and Current Inputs



ATTENTION

Make sure that your model of DTS 310 is approved for the following wiring guidelines.

Note: CTs should be connected to the same panel as the voltage connections.

3.1.1 Wiring Examples

Load →

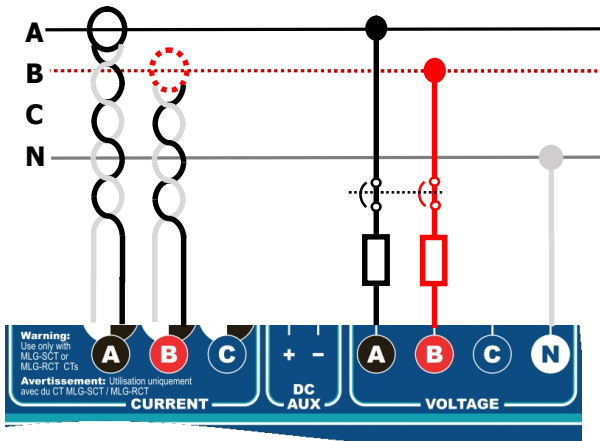

Single Phase 2/3 Wire

Load →

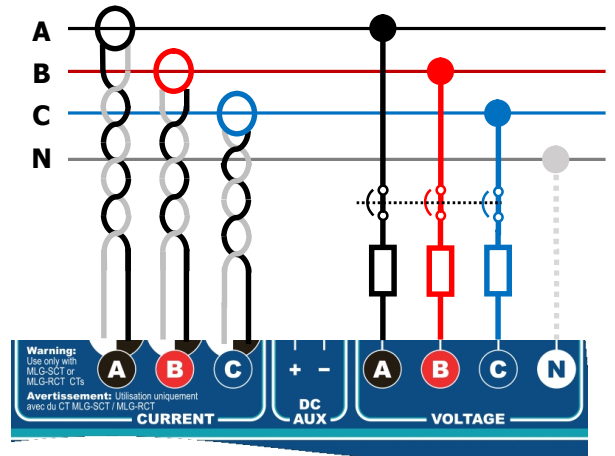

3-Phase with Optional Neutral (Model Dependent)

3.2 Connecting Multiple Loads

The DTS 310 allows for ease and flexibility when monitoring multiple branches. The DTS 310 allows multiple CT sensors to be connected in parallel via the green pluggable screw terminal.

When using parallel CT sensors, the following guidelines must be followed to ensure accurate measuring.

- All CT sensors must have a 333mV output.
- All CT sensors must be of the same manufacturer/model number and current rating.
- A full set of CT sensors must be used for each load.
- The pair of wires from the CT sensor to the green pluggable screw terminal must be twisted.
- All CT sensors must be terminated at the green pluggable screw terminal.
- A maximum of 3 loads can be monitored at once (Contact Measurlogic if more than 3 loads must be monitored).
- The measured phase current will be the total current across all the loads on that phase.
- The CT primary rating for the DTS 310 must be set to the **CT rating * Number of CT sets**.
- The example below shows how to calculate the service current for figure 3.2.1.

Service Current for Figure 3.2.1	
Number of CT Sensor Sets	2
CT Rating	100 Amps
CT Primary	200 Amps

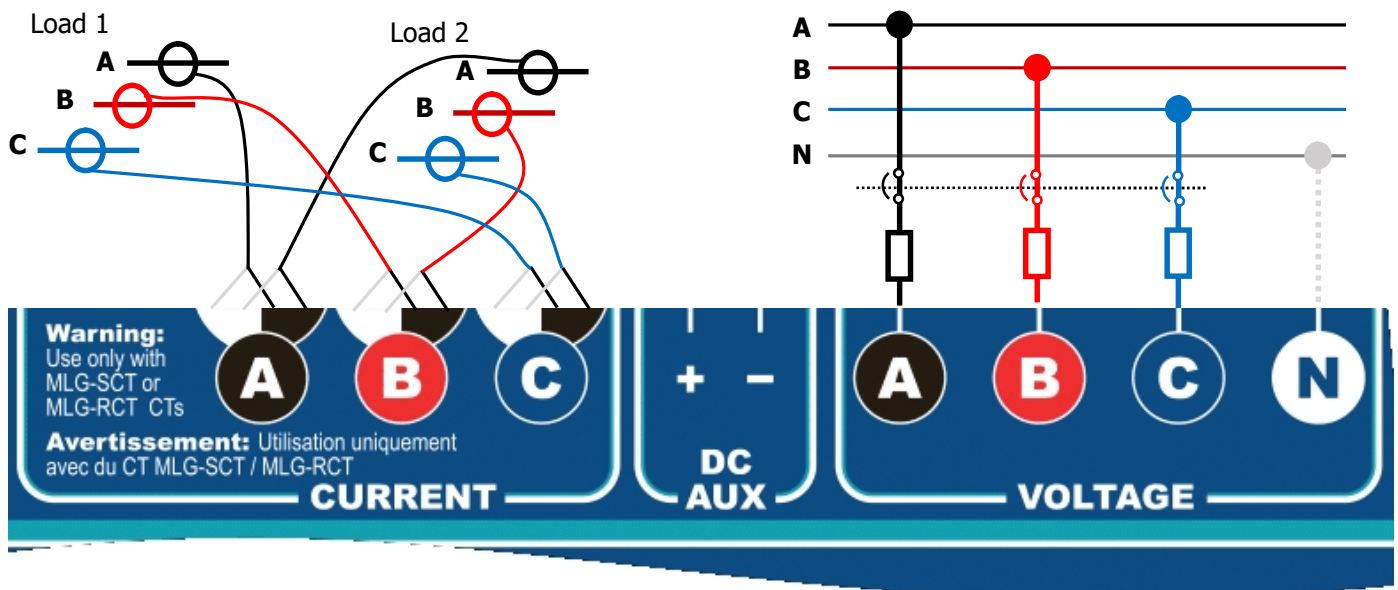

3.3 DC Auxiliary Power

The most common way to power the DTS 310 meter is through the voltage connections. If this situation is not ideal the DTS 310 meter can be powered through a **user supplied DC source**.



ATTENTION

Check the DTS 310 model number for the correct DC voltage to power the DTS 310 through the auxiliary.

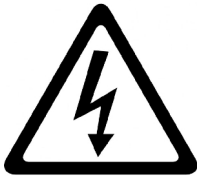

WARNING

Make sure that all power is removed from the DTS 310 prior to wiring the DC auxiliary

DTS 310 - XX-XX-X-**F**-XX

Service Type	Value	Description
F	1	12Vdc external power
	3	24 Vdc external power
	5	48 Vdc external power

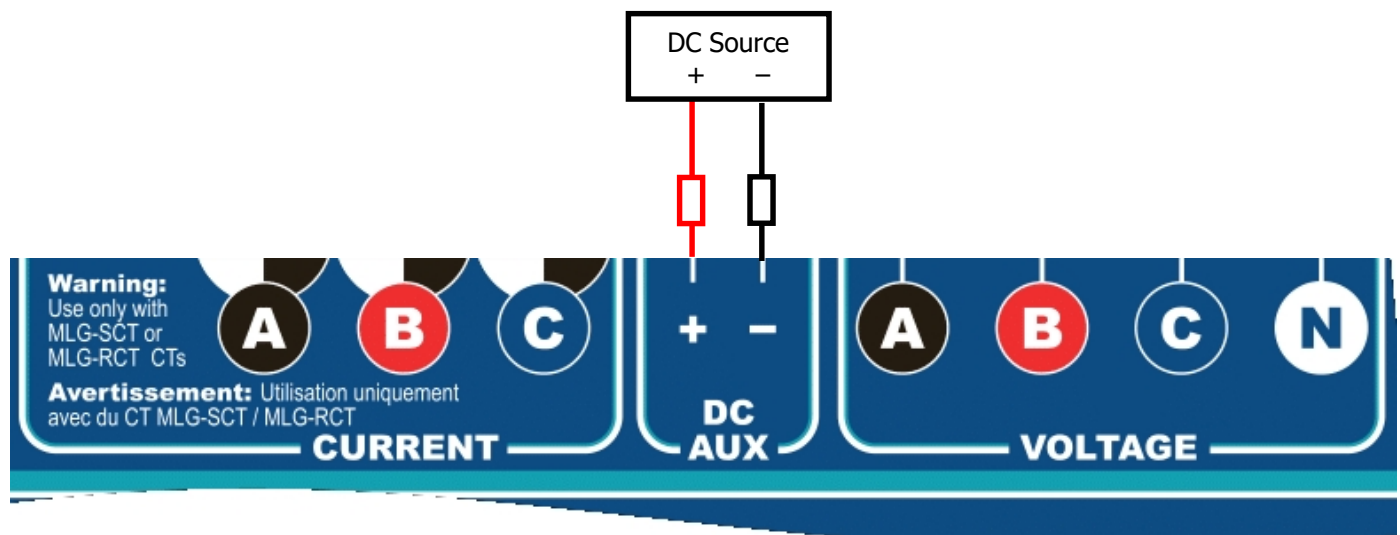

4 Maintenance and Service



ATTENTION

There are **NO** user serviceable parts in the DTS 310, and no regular maintenance is required. If additional maintenance is needed, please contact Measurlogic Inc.

5 DTS 310 COMMUNICATIONS INTERFACE

The DTS 310 has 4 options for outputting data as well as the several communication protocols **depending on the model ordered**:

- 2-Wire RS-485 bus
 - Modbus RTU
 - BACnet MS/TP
- LonWorks TP/FT - 10
- Ethernet Communications
 - Modbus TCP
 - BACnet/IP
- A kWh Energy Pulse Output through a Potential-Free Normally Open (N.O.) Solid State Relay (SSR).

Do NOT use this output to switch more than 50Vdc.

5.1 Modbus and BACnet RS-485 2-Wire Communications

RS-485 is a Daisy Chained Bus terminated at both ends with 120 Ohms. DO NOT use a STAR or RING configuration.

- Use 18-22 AWG, 2-core, shielded, twisted pair cable.
- When fitted with **Modbus RTU**, unless otherwise stated through correspondence prior to ordering or specified on the label of the DTS 310 unit, the default communications parameters are as follows:
 - Modbus Address: 100, Baud Rate: 9600, Parity: None, Data Bits: 8, Stop Bits: 1. This is notated as **9600, N, 8, 1 #100**.
- Modbus parameters can be changed either through **DTS Config** or by writing to specific registers in the meter. Please see the **Modbus Map** document or section 7 for **DTS Config**.
- When fitted with **BACnet MS/TP**, unless otherwise stated through correspondence prior to ordering or specified on the label of the DTS 310 unit, the default communications parameters are as follows:
 - Device Object ID: 100, MAC Address: 100, Baud Rate: 38400, Parity: None, Data Bits: 8, Stop Bits: 1. This is notated as **38400, N, 8, 1 #100**.
- BACnet parameters must be changed via the BACnet interface.

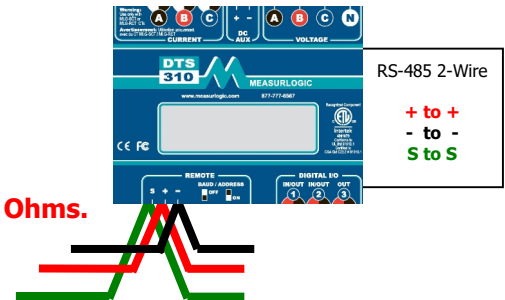

5.2 LonWorks TP/FT – 10 Communications

5.2.1 Wiring Requirements

- The LonWorks model of the DTS 310 has a 2-wire TP/FT – 10 communications port.
- Use 18-22 AWG; 2 core; twisted pair cable.
- LonWorks TP/FT – 10 ports are **non-polarity sensitive**.
- DTS 310 meters fitted with LonWorks TP/FT – 10 communications can be wired in bus, star, or ring topologies.

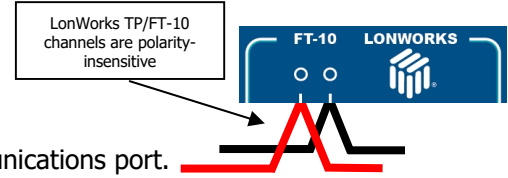

5.2.2 Adding the DTS 310 to an existing LonWorks Network via Service Pin

- Open the clear hinged faceplate of the DTS 310.
- Press the Measurlogic logo located on the front of the DTS 310. The LonWorks service pin is located behind the Measurlogic Logo.
- While the Measurlogic logo is pressed, the Service LED also located on the front of the DTS 310 should light up RED until the logo is released.

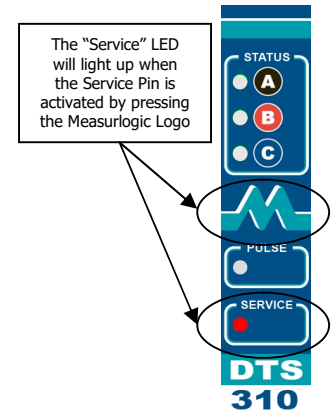

5.2.3 Adding the DTS 310 to an existing LonWorks Network via Neuron ID

- The unique Neuron ID can be located on the side label of the DTS 310 and is referred to as **NID**.

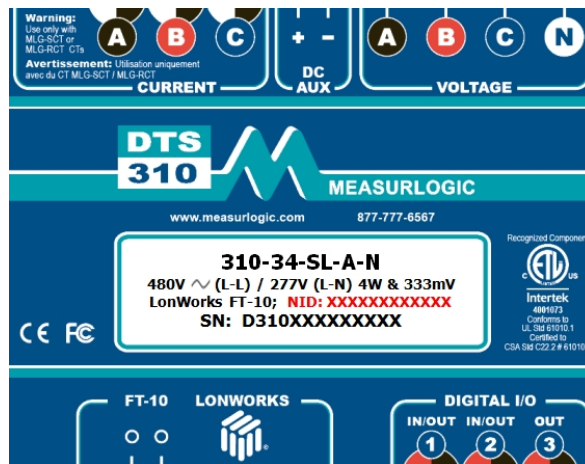

5.3 Ethernet Communications

- Ethernet connection is available through the RJ45 socket located on the side of the DTS Meter.
- Modbus TCP, BACnet/IP, SNMP, and DNP3 are available protocols **depending on model ordered**.
- Modbus TCP comes along side any other protocol ordered.
- Default IP address of the DTS 310 meter is **192.168.1.150**.
- **Default Modbus Address, BACnet Device ID, and DNP3 address is 100.**
- IP address can be configured through the **DTS Toolbox** utility. DTS Toolbox can be downloaded at <http://www.measurlogic.com/software>.

5.4 kWh Pulse Output (Model Dependent)

- The DTS 310 comes with a Digital I/O port that can be configured for pulse outputs.
- The DTS 310 will pulse at 1kWh by default but can be changed using DTS Config or by setting the DIP switches found on the side of the meter.
- The relay closure of each pulse will last for 100ms (pulse width) with a minimum delay of 100ms between any two pulses.
The maximum switching voltage is 50Vdc.
- Digital I/O pins 1 and 2 are not used for kWh Pulse.

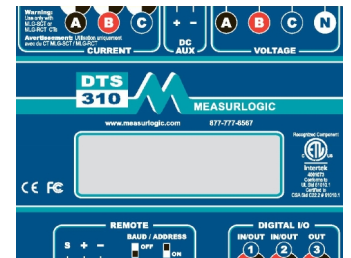

Digital Input module
or Counter

5.5 Configuring DIP Switches – Communication and Pulse Output Settings

DTS 310 meters fitted with Modbus RTU or BACnet MS/TP communications or Pulse Outputs come with configurable dip switches on the side of the DTS meter next to the communications port and can be black or red.

Check the model of the DTS 310 to determine what the DIP switches will do.

The switches are used to manually configure:

- Modbus Address
- BACnet ID
- Baud Rate
- CT Primary
- Pulse Output



ATTENTION

DIP switches should be set with the power completely removed from the DTS 310. DIP switch settings will overwrite any settings done through software until the DIP switches are turned OFF.

5.5.1 Configuring DIP Switches – Modbus RTU

The following table shows how to use the DIP Switches to manually configure a DTS 310 for a Modbus RTU network.

- The Modbus Address is set by flipping the switches 2-8 ON (▼) that add up to the desired address. Leave any unused switch OFF (▲).
- Example: To configure an address of 100 flip switches 2, 3, and 6 ON (▼)
64 + 32 + 4 = 100.

Description	Switch Position							
	1	2	3	4	5	6	7	8
Modbus Address		64	32	16	8	4	2	1
9600 Baud Rate	Off ▲							
19200 Baud Rate	On ▼							
Software Configurable Setting	Off ▲	Off ▲	Off ▲	Off ▲	Off ▲	Off ▲	Off ▲	Off ▲

5.5.2 Configuring DIP Switches – BACnet MS/TP

The following table shows how to use the DIP Switches to manually configure a DTS 310 for a BACnet MS/TP network.

- The Device ID and MAC address is set by flipping the switches 2-8 ON (▼) that add up to the desired ID and MAC. Leave any unused switch OFF (▲).
- Example: To configure a BACnet ID and MAC address of 100 flip switches 2,3, and 6 ON (▼)
64 + 32 + 4 = 100.

Description	Switch Position							
	1	2	3	4	5	6	7	8
Device ID & MAC Address		64	32	16	8	4	2	1
9600 Baud Rate	Off ▲							
38400 Baud Rate	On ▼							
Software Configurable Setting	Off ▲	Off ▲	Off ▲	Off ▲	Off ▲	Off ▲	Off ▲	Off ▲

5.5.3 Configuring DIP Switches – Pulse Output

The following tables show how to manually set the CT Primary (CT Rating) as well as some preset pulse outputs.

- Switch 3 is not used when configuring Pulse Outputs and should remain OFF (▲).

Switch 4-8 (Current "CT" Primary Selection)

CT Primary	SW 4	SW 5	SW 6	SW 7	SW 8
Custom	Off ▲	Off ▲	Off ▲	Off ▲	Off ▲
1	Off ▲	Off ▲	Off ▲	Off ▲	On ▼
5	Off ▲	Off ▲	Off ▲	On ▼	0
20	Off ▲	Off ▲	Off ▲	On ▼	On ▼
25	Off ▲	Off ▲	On ▼	Off ▲	Off ▲
50	Off ▲	Off ▲	On ▼	Off ▲	On ▼
75	Off ▲	Off ▲	On ▼	On ▼	Off ▲
100	Off ▲	Off ▲	On ▼	On ▼	On ▼
125	Off ▲	On ▼	Off ▲	Off ▲	Off ▲
150	Off ▲	On ▼	Off ▲	Off ▲	On ▼
200	Off ▲	On ▼	Off ▲	On ▼	Off ▲
250	Off ▲	On ▼	Off ▲	On ▼	On ▼
300	Off ▲	On ▼	On ▼	Off ▲	Off ▲
400	Off ▲	On ▼	On ▼	Off ▲	On ▼
450	Off ▲	On ▼	On ▼	On ▼	Off ▲
500	Off ▲	On ▼	On ▼	On ▼	On ▼
600	On ▼	Off ▲	Off ▲	Off ▲	Off ▲
750	On ▼	Off ▲	Off ▲	Off ▲	On ▼
800	On ▼	Off ▲	Off ▲	On ▼	Off ▲
900	On ▼	Off ▲	Off ▲	On ▼	On ▼
1000	On ▼	Off ▲	On ▼	Off ▲	Off ▲
1200	On ▼	Off ▲	On ▼	Off ▲	On ▼
1500	On ▼	Off ▲	On ▼	On ▼	Off ▲
1600	On ▼	Off ▲	On ▼	On ▼	On ▼
2000	On ▼	On ▼	Off ▲	Off ▲	Off ▲
2500	On ▼	On ▼	Off ▲	Off ▲	On ▼
3000	On ▼	On ▼	Off ▲	On ▼	Off ▲
4000	On ▼	On ▼	Off ▲	On ▼	On ▼
5000	On ▼	On ▼	On ▼	Off ▲	Off ▲

Switch 1-2 (Pulse Output Mappings)

SW 1	SW 2	Mapping
Off ▲	Off ▲	Preset Custom
Off ▲	On ▼	1 pulse / 0.1kWh
On ▼	Off ▲	1 pulse / 0.5kWh
On ▼	On ▼	1 pulse / 1.0kWh (Default)

6 LED Definitions

The DTS 310 is equipped with 3 LEDs useful for diagnostics and troubleshooting – **STATUS**, **REMOTE**, and **PULSE**.

6.1 Status LED

- The **STATUS** LED consists of a repetition of **two flashes** and shows whether the measured power is being consumed/imported or generated/exported, as well as the magnitude of the total current.
- The **First Flash** is the “heartbeat” and indicates that the meter is ON and the direction of energy:



Green – Energy is being consume/imported



Orange – Energy is being generated/exported

- The Color and Length of the **Second Flash** indicates the “total current level” for all the measured phases relative to the total service current:

- **GREEN** for 5-80% of total service current
- **ORANGE** for 80-100% of total service current
- **RED** for >100% of total service current

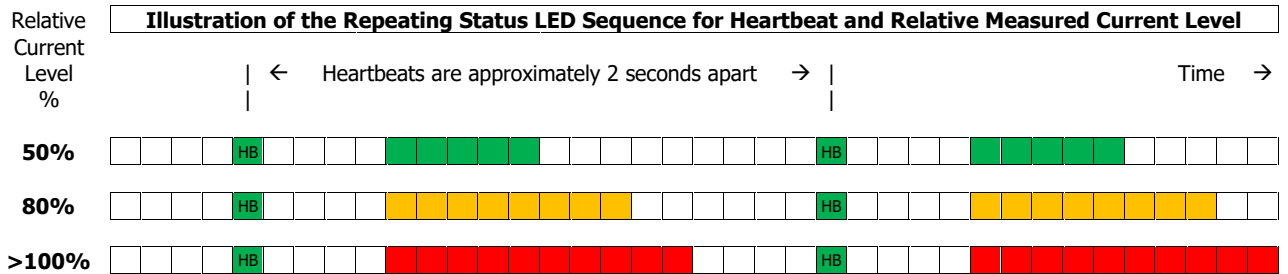

6.2 Remote LED

- The **REMOTE** LED is a communications indicator which is present on all meters fitted with an RS-485 serial port.
- The LED will flicker **GREEN** when the DTS 310 receives data on the BUS and **AMBER** when the DTS 310 transmits data in response.



Green – Data being received



Amber – Data being transmitted

6.3 Pulse LED

- The **PULSE** LED is an indicator LED that flashes amber every time the measured kWh passes a settable threshold.

7 INSTALLATION OF DTS CONFIG AND MONITORING SOFTWARE

- DTS Config** is a program used to easily monitor and configure meters from the DTS family from your local PC or across the LAN.
- Download the latest version of DTS Config from <http://www.measurlogic.com/software>. Alternatively, an e-mail can be sent to info@measurlogic.com to request the latest version of DTS Config.
- Unzip the **DTSTConfigSetup** file and double click the **setup.exe** file to begin the installation process.
- Follow the instructions on the screen.

8 MAINTENANCE AND SERVICE

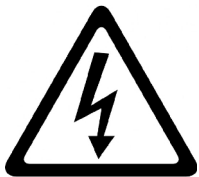

WARNING

There are NO other user serviceable parts in the DTS 310, and no regular maintenance is required. If additional maintenance is needed, please contact Measurlogic Inc.

8.1 Cleaning Instructions

Regular cleaning of the DTS 310 is **NOT** required, but if you do wish to clean the DTS 310, please note the following:

- Before attempting to clean the DTS 310 ensure that all power running to the DTS 310 is removed.
- Use only a slightly damp cloth to clean the outside of the meter only.**
- Do not use any harsh chemicals or detergents.
- No water or any other liquid must be allowed to enter the meter.
- Do not use a spray bottle.